

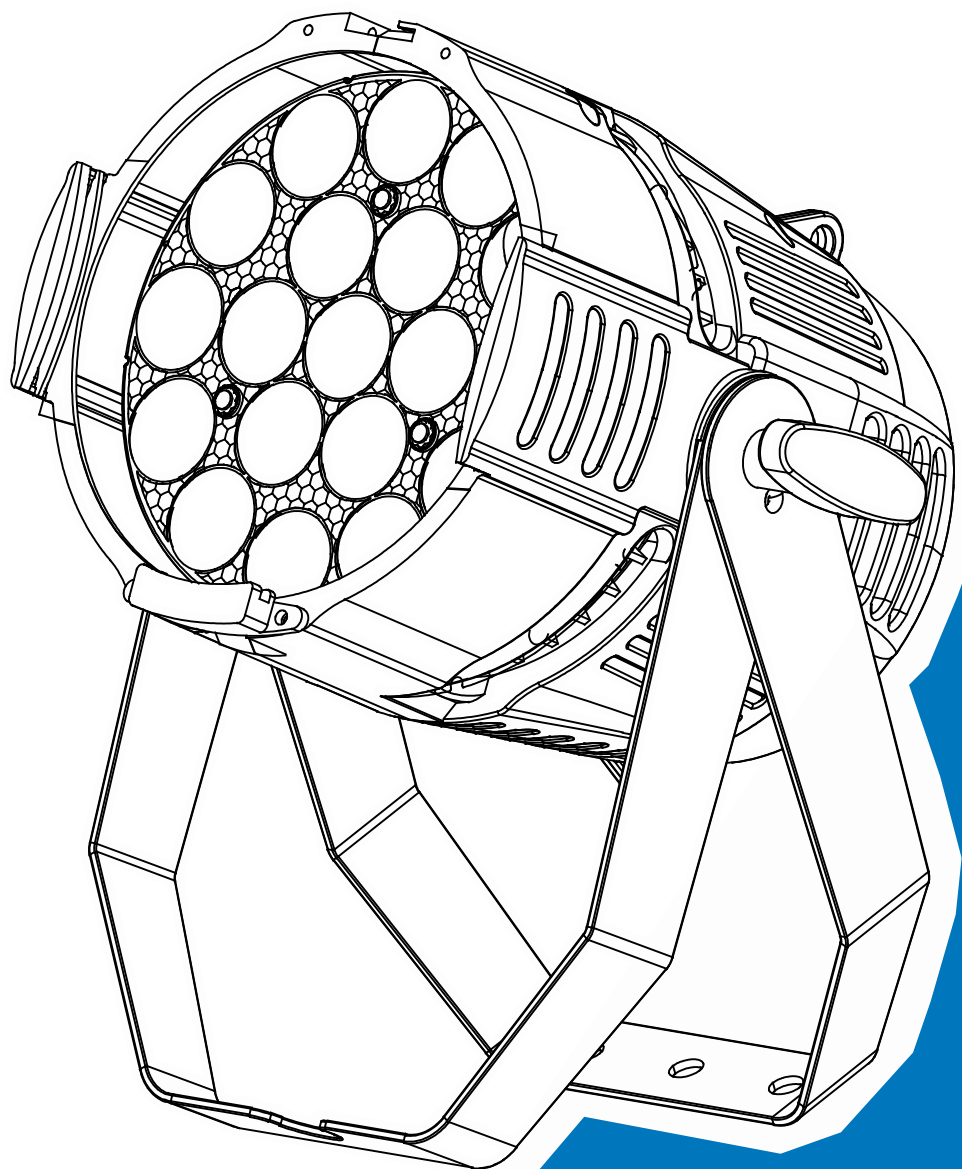

STAGE PAR 300 ZOOM



User Manual

Please read the instruction carefully before use

CONTENTS

1. Safety Instructions	2
2. Technical Specifications.....	3
3. How To Set The Unit.....	4
3.1 Control Panel.....	4
3.2 Main Functions	5
4. How to Control the Unit	9
4.1 DMX Controller	10
4.2 DMX 512 Configurations	11
5. DMX 512 Connections.....	11
6. Troubleshooting	13
7. Fixture Cleaning	13

1. Safety Instructions



Please read the instruction carefully which includes important information about the installation, usage and maintenance.

WARNING

- Please keep this User Guide for future consultation. If you sell the unit to another user, be sure that they also receive this instruction booklet.
- Please unpack and check carefully there is no transportation damage before using the unit.
- Before operating, ensure that the voltage and frequency of power supply match the power requirements of the unit.
- It's important to ground the yellow/green conductor to earth in order to avoid electric shock.
- The unit is for indoor use only. Use only in a dry location.
- The unit must be installed in a location with adequate ventilation, at least 50cm from adjacent surfaces. Be sure that no ventilation slots are blocked.
- Please disconnect main power before replacement or servicing.
- Please make sure there are no flammable materials close to the unit while operating as it is fire hazard.
- Please use safety cable when fixes this unit. DO NOT handle the unit by taking its head only, but always by taking its base.
- Maximum ambient temperature is $T_a: 40^{\circ}\text{C}$. DO NOT operate it where the temperature is higher than this.
- Unit surface temperature may reach up to 85°C . DO NOT touch the housing bare-hand during its operation. Turn off the power and allow about 15 minutes for the unit to cool down before replacing or serving.
- In the event of serious operating problem, stop using the unit immediately. Never try to repair the unit by yourself. Repairs carried out by unskilled people can lead to damage or malfunction. Please contact the nearest authorized technical assistance center. Always use the same type spare parts.
- DO NOT touch any wire during operation as high voltage might be causing electric shock.

Warning:

- To prevent or reduce the risk of electrical shock or fire, do not expose the unit to rain or moisture.
- DO NOT open the unit within five minutes after switching off.
- The housing, the lenses, or the ultraviolet filter must be replaced if they are visibly damaged.

Caution:

There are no user serviceable parts inside the unit. DO NOT open the housing or attempt any repairs yourself. In the unlikely event your unit may require service, please contact your nearest dealer.

Installation:

The unit should be mounted via its screw holes on the bracket. Always ensure that the unit is firmly fixed to avoid vibration and slipping while operating. And make sure that the structure to which you are attaching the unit is secure and is able to support a weight of 10 times of the unit's weight. Also always use a safety cable that can hold 12 times of the weight of the unit when installing the fixture.

The equipment must be fixed by professionals. And it must be fixed at a place where is out of the touch of people and has no one pass by or under it.

2. Technical Specifications

- ◇ DMX 512 Channels: 5/6/8 channels
- ◇ Perfect strobe with smooth dimming 0~100%
- ◇ Two Operation Modes: DMX, Master/Slave
- ◇ Suitable for discos, clubs, bars, parties and mobile DJs, etc.

- **Power Voltage:** AC 100~240V, 50/60Hz
- **Power Consumption:** 230W
- **Light Source:** 19 × 15W RGBW LED
- **Fuse:** T 6.3A
- **Beam Angle:** 10°~60°
- **Dimension/Weight:** 324×276×368mm, 7.2kgs
12.7"x10.9"x14.5" in, 15.9lbs

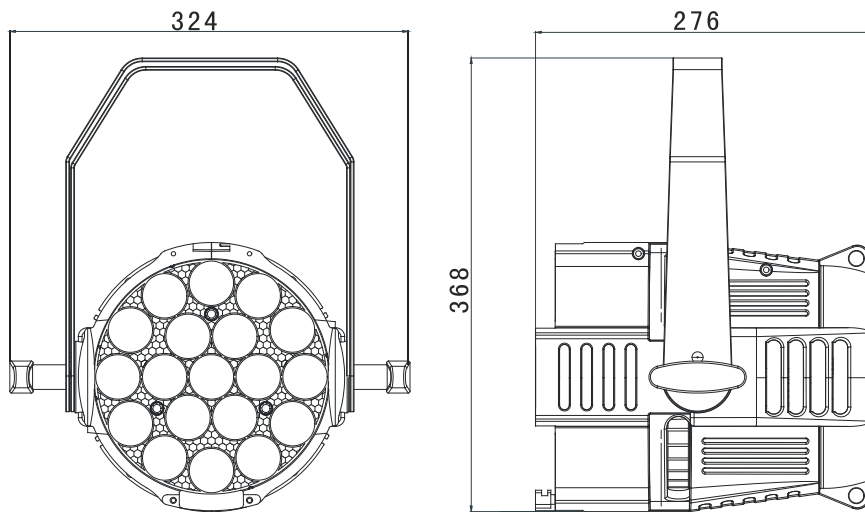

3. How To Set The Unit

3.1 Control Panel

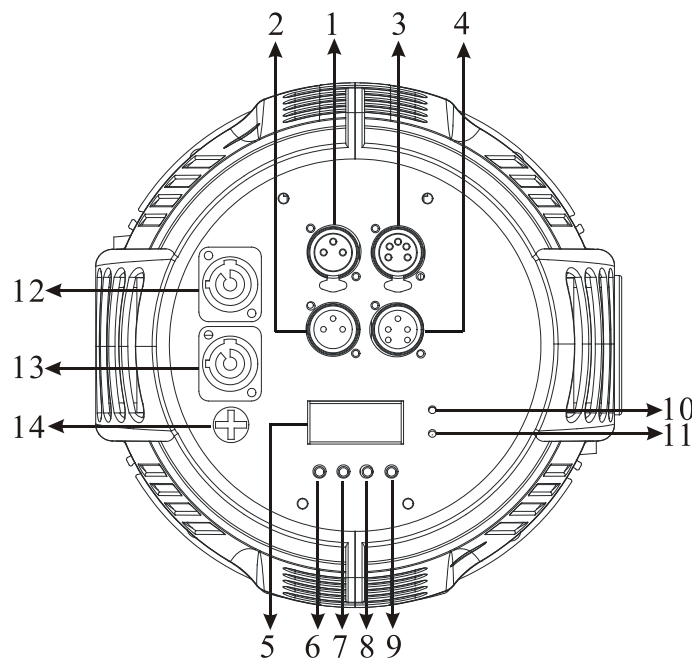

1. **DMX IN:** For DMX512 link, use 3-pin XLR plug cable to input DMX512 single
2. **DMX OUT:** For DMX512 link, use 3-pin XLR plug cable to output DMX512 single to the next unit
3. **DMX IN:** For DMX512 link, use 5-pin XLR plug cable to input DMX single
4. **DMX OUT:** For DMX512 link, use 5-pin XLR plug cable to output DMX512 single to the next unit
5. **Display:** To show the various menus and the selected functions

Button:

6. MENU	To select the programming functions
7. DOWN	To go forward in the selected functions
8. UP	To go backward in the selected functions
9. ENTER	To confirm the selected functions

LED:

10. POWER	On	Power On
11. DMX	On	DMX input present

12. **POWER IN:** Connect to supply power for the fixture
13. **POWER OUT:** Connect to supply power to the next fixture
14. **Fuse (T 6.3A):** Protect the fixture from damage of current

3.2 Main Functions

To select any of the given functions, press the **MENU** button up to when the required one is showing on the display. Select the function by the **ENTER** button and the display will blink. Use the **DOWN** and **UP** button to change the mode. Once the required mode has been selected, press the **ENTER** button to setup, to go back to the functions without any change press the **MENU** button again. Hold and press the **MENU** button about one second or wait for one minute to exit the menu mode.

The main functions are showing below:

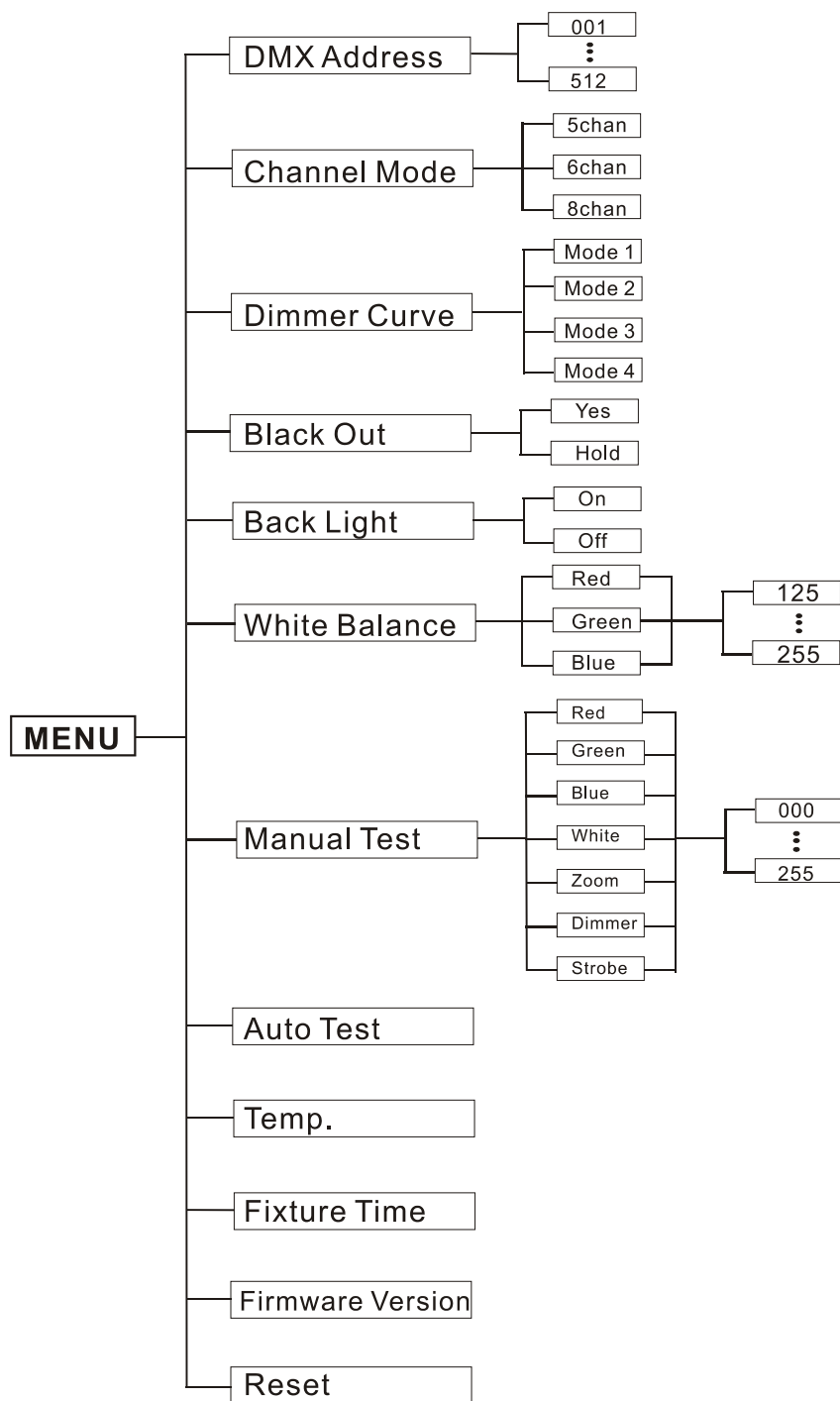

DMX Address

Select the **DMX Address**, press the **ENTER** button and the display will blink. Use the **DOWN** and **UP** button to change the DMX 512 Address, and then press the **ENTER** button to save. Back to the previous functions without any change press the **MENU** button.

Channel Mode

Select the **Channel Mode**, press the **ENTER** button and the display will blink. Use the **DOWN** and **UP** button to select the **5chan**, **6chan** or **8chan** mode. Once the mode has been selected, press the **ENTER** button to save or automatically exit menu mode without any change. Back to the previous functions without any change press the **MENU** button.

Dimmer Curve

Select **Dimmer Curve**, press the **ENTER** button to confirm, present mode will blink on the display. Use the **DOWN** and **UP** button to select the **Mode1** or **Mode 2** or **Mode 3** or **Mode 4**. Once the mode has been selected, press the **ENTER** button to setup, to go back to the functions without any change press the **MENU** button again. Hold and press the **MENU** button about one second or wait for one minute to exit the menu mode.

Dimmer Modes

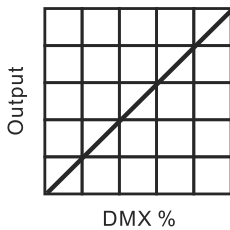

Optically Linear

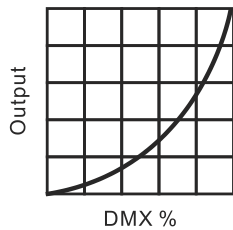

Square Law

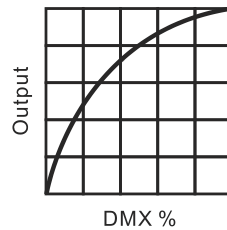

Inverse Square Law

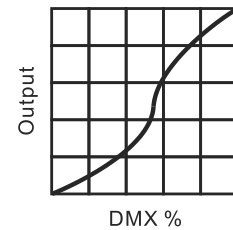

S-curve

Mode 1 (Optically Linear): The increase in light intensity appears to be linear as DMX value is increased.

Mode 2 (Square Law): Light intensity control is finer at low levels and coarser at high levels.

Mode 3 (Inverse Square Law): Light intensity control is coarser at low levels and finer at high levels.

Mode 4 (S-curve): Light intensity control is finer at low levels and high levels and coarser at medium levels.

Black Out

Select the **Black Out**, press the **ENTER** button and the display will blink. Use the **DOWN** and **UP** button to select the **Yes** (blackout) or **Hold** (keep the present status). Once selected, press the **ENTER** button to save or automatically exit menu mode without any change. Back to the previous functions without any change press the **MENU** button.

Back Light

Select the **Back Light**, press the **ENTER** button and the display will blink. Use the **DOWN** and **UP** button to select the **On** or **Off**. Once selected, press the **ENTER** button to save or automatically exit menu mode without any change. Back to the previous functions without any change press the **MENU** button.

White Balance

Select the **White Balance**, press the **ENTER** button and the display will blink. Use the **DOWN** and **UP** button to find the color (**Red, Green, Blue**) you wish to adjust. Press the **ENTER** button to confirm and use **DOWN** and **UP** button to adjust the value (**125~255**), once select press **ENTER** button to setup. To go back to the last function without any change press the **MENU** button.

Manual Test

Select the **Manual Test**, press the **ENTER** button and the display will blink. Use the **DOWN** and **UP** button to find the **Red, Green, Blue, White, Zoom, Dimmer** or **Strobe**. Once you find a function or color you wish to test, press the **ENTER** button, the displayed value will begin to flash. You can now adjust the values (**000~255**) by pressing the **DOWN** and **UP** button. Once you have finished testing press the **ENTER** button. To go back to the last function without any change press the **MENU** button.

Auto Test

Select the **Auto Test**, press the **ENTER** button, the unit will run the built-in programmer for self test.

Press the **MENU** button to exit.

Temp.

Select the **Temp.** , press the **ENTER** button and the display will show the current running temperature of the fixture. Press the **MENU** button to exit.

Fixture Time

Select the **Fixture Time**, press the **ENTER** button and the display will show the running time of the fixture. Press the **MENU** button to exit.

Firmware Version

Select the **Firmware Version**, press the **ENTER** button and the display will show the software version of the fixture. Press the **MENU** button to exit.

Reset

Select the **Reset**, press the **ENTER** button and the fixture will now reset.

4. How to Control the Unit

Please access the fixture in two ways:

1. By master/slave built-in preprogram function
2. By DMX controller

No need to turn the fixture off when you change the DMX address, as new DMX address setting will be affected at once. Every time you turn the fixture on, it will show “MP-300Z II” on the display and move all the motors to their ‘home’ position. After that the fixture will be ready to receive DMX signal or run the built in programs.

4.1 DMX Controller

Use universal DMX controller to control the fixtures, you have to set DMX address from 1 to 512 channel so that the units can receive DMX signal.

Press the **MENU** button, select the **DMX Address**. Pressing the **ENTER** button and the display will blink. Use the **DOWN** and **UP** button to change the DMX512 address. Once the address has been selected, press and keep **ENTER** button to save. To go back to the functions without any change press the **MENU** button again.

If you use please refer to the following diagram to address your DMX512 channel for the first 4 fixtures.

Channel Mode	Fixture 1 Address	Fixture 2 Address	Fixture 3 Address	Fixture 4 Address
5 channels	1	6	11	16
6 channels	1	7	13	19
8 channels	1	9	17	25

4.2 DMX 512 Configurations

5/6/8 Channels Mode:

DMX512 Configurations																																											
5 Channels Mode					6 Channels Mode																																						
Ch1	Ch2	Ch3	Ch4	Ch5	Ch1	Ch2	Ch3	Ch4	Ch5	Ch6																																	
RED	GREEN	BLUE	WHITE	ZOOM	RED	GREEN	BLUE	WHITE	DIMMER	ZOOM																																	
<table border="1"> <thead> <tr> <th colspan="8">8 Channels Mode</th> </tr> <tr> <th>Ch1</th> <th>Ch2</th> <th>Ch3</th> <th>Ch4</th> <th>Ch5</th> <th>Ch6</th> <th>Ch7</th> <th>Ch8</th> </tr> <tr> <th>RED</th> <th>GREEN</th> <th>BLUE</th> <th>WHITE</th> <th>DIMMER</th> <th>STROBE</th> <th>COLOR</th> <th>ZOOM</th> </tr> </thead> <tbody> <tr> <td></td> <td></td> <td></td> <td></td> <td></td> <td> 248-255 Open 240-247 Random Strobe 232-239 Open 190-231 Slow Close Fast Open 182-189 Open 140-181 Slow Open Fast Close 132-139 Open 016-131 ⚡ 008-015 ⚡ 000-007 Off </td> <td> 248-255 Preset color32 241-247 Preset color31 233-240 Preset color30 225-232 Preset color29 217-224 Preset color28 210-216 Preset color27 202-209 Preset color26 194-201 Preset color25 186-193 Preset color24 179-185 Preset color23 171-178 Preset color22 163-170 Preset color21 155-162 Preset color20 148-154 Preset color19 140-147 Preset color18 132-139 Preset color17 124-131 Preset color16 117-123 Preset color15 109-116 Preset color14 101-108 Preset color13 093-100 Preset color12 086-092 Preset color11 078-085 Preset color10 070-077 Preset color9 062-069 Preset color8 055-061 Preset color7 047-054 Preset color6 039-046 Preset color5 031-038 Preset color4 024-030 Preset color3 016-023 Preset color2 008-015 Preset color1 000-007 Open </td> <td></td> </tr> </tbody> </table>												8 Channels Mode								Ch1	Ch2	Ch3	Ch4	Ch5	Ch6	Ch7	Ch8	RED	GREEN	BLUE	WHITE	DIMMER	STROBE	COLOR	ZOOM						248-255 Open 240-247 Random Strobe 232-239 Open 190-231 Slow Close Fast Open 182-189 Open 140-181 Slow Open Fast Close 132-139 Open 016-131 ⚡ 008-015 ⚡ 000-007 Off	248-255 Preset color32 241-247 Preset color31 233-240 Preset color30 225-232 Preset color29 217-224 Preset color28 210-216 Preset color27 202-209 Preset color26 194-201 Preset color25 186-193 Preset color24 179-185 Preset color23 171-178 Preset color22 163-170 Preset color21 155-162 Preset color20 148-154 Preset color19 140-147 Preset color18 132-139 Preset color17 124-131 Preset color16 117-123 Preset color15 109-116 Preset color14 101-108 Preset color13 093-100 Preset color12 086-092 Preset color11 078-085 Preset color10 070-077 Preset color9 062-069 Preset color8 055-061 Preset color7 047-054 Preset color6 039-046 Preset color5 031-038 Preset color4 024-030 Preset color3 016-023 Preset color2 008-015 Preset color1 000-007 Open	
8 Channels Mode																																											
Ch1	Ch2	Ch3	Ch4	Ch5	Ch6	Ch7	Ch8																																				
RED	GREEN	BLUE	WHITE	DIMMER	STROBE	COLOR	ZOOM																																				
					248-255 Open 240-247 Random Strobe 232-239 Open 190-231 Slow Close Fast Open 182-189 Open 140-181 Slow Open Fast Close 132-139 Open 016-131 ⚡ 008-015 ⚡ 000-007 Off	248-255 Preset color32 241-247 Preset color31 233-240 Preset color30 225-232 Preset color29 217-224 Preset color28 210-216 Preset color27 202-209 Preset color26 194-201 Preset color25 186-193 Preset color24 179-185 Preset color23 171-178 Preset color22 163-170 Preset color21 155-162 Preset color20 148-154 Preset color19 140-147 Preset color18 132-139 Preset color17 124-131 Preset color16 117-123 Preset color15 109-116 Preset color14 101-108 Preset color13 093-100 Preset color12 086-092 Preset color11 078-085 Preset color10 070-077 Preset color9 062-069 Preset color8 055-061 Preset color7 047-054 Preset color6 039-046 Preset color5 031-038 Preset color4 024-030 Preset color3 016-023 Preset color2 008-015 Preset color1 000-007 Open																																					

5. DMX 512 Connections

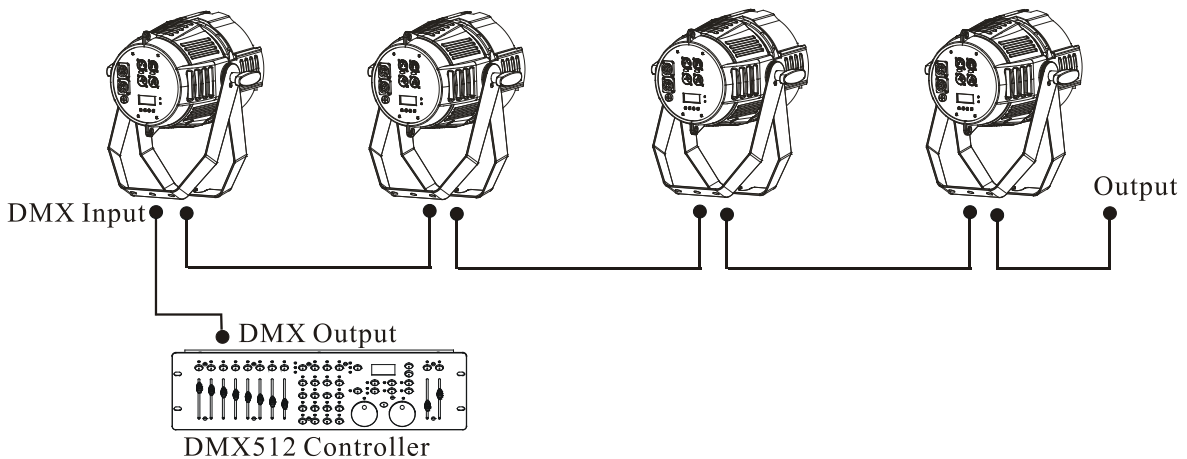

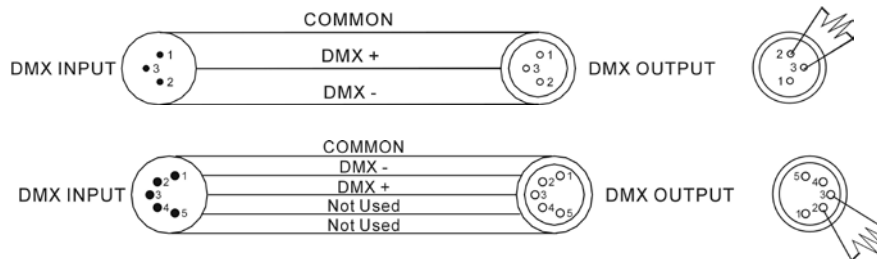

1. If you using a controller with 5 pins DMX output, you need to use a 5 to 3 pin adapter-cable.
2. At last unit, the DMX cable has to be terminated with a terminator. Solder a 120 ohm 1/4W resistor between pin 2(DMX-) and pin 3(DMX+) into a 3-pin XLR-plug and plug it in the DMX-output of the last unit.
3. Connect the unit together in a `daisy chain` by XLR plug from the output of the unit to the input of the next unit. The cable can not branched or split to a `Y` cable. DMX 512 is a very high-speed signal. Inadequate or damaged cables, soldered joints or corroded connectors can easily distort the signal and shut down the system.
4. The DMX output and input connectors are pass-through to maintain the DMX circuit, when one of the units' power is disconnected.
5. Each lighting unit needs to have an address set to receive the data sent by the controller. The address number is between 0-511 (usually 0 & 1 are equal to 1).
6. The end of the DMX 512 system should be terminated to reduce signal errors.
7. 3 pin XLR connectors are more popular than 5 pin XLR.
 - 3 pin XLR: Pin 1: GND, Pin 2: Negative signal (-), Pin 3: Positive signal (+)
 - 5 pin XLR: Pin 1: GND, Pin 2: Negative signal (-), Pin 3: Positive signal (+),
Pin 4/Pin 5: Not used.

6. Troubleshooting

Following are a few common problems that may occur during operation. Here are some suggestions for easy troubleshooting:

A. The unit does not work, no light and the fan does not work

1. Check the connection of power and main fuse.
2. Measure the mains voltage on the main connector.
3. Check the power on LED.

B. Not responding to DMX controller

1. DMX LED should be on. If not, check DMX connectors, cables to see if link properly.
2. If the DMX LED is on and no response to the channel, check the address settings and DMX polarity.
3. If you have intermittent DMX signal problems, check the pins on connectors or on PCB of the unit or the previous one.
4. Try to use another DMX controller.
5. Check if the DMX cables run near or run alongside to high voltage cables that may cause damage or interference to DMX interface circuit.

C. One of the channels is not working well

1. The stepper motor might be damaged or the cable connected to the PCB is broken.
2. The motor's drive IC on the PCB might be out of condition

7. Fixture Cleaning

The cleaning must be carried out periodically to optimize light output. Cleaning frequency depends on the environment in which the fixture operates: damp, smoky or particularly dirty surrounding can cause greater accumulation of dirt on the unit's optics.

- Clean with soft cloth using normal glass cleaning fluid.
- Always dry the parts carefully.
- Clean the external optics at least every 30 days.

Innovation, Quality, Performance