

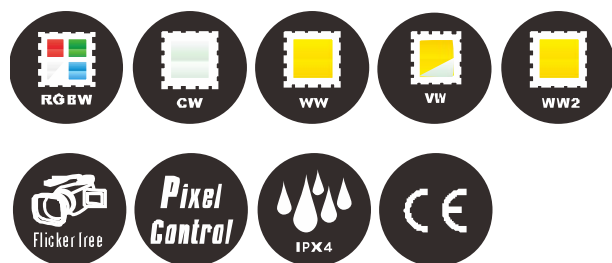

ACME<sup>®</sup>  
JAPAN

# STAGE BLINDER IP BL-200



## 製品特徴

- ・最大8灯までの連結が可能
- ・2灯を個別で制御可能
- ・0~100%スムーズ調光
- ・パリアブルストロボスピード



## 製品仕様

- ・光源 : 2 x 110W (CW/WW)  
2 x 125W (VW/WW2)  
2 x 150W (RGBW)
- ・色温度 : 2700±200K (WW)  
2700K (WW2)/1200K(Tungsten mode)  
5000±300K (CW)  
2700~6500K (VW)  
2000~10000K (RGBW)
- ・ズーム : 50° (CW/WW)  
50°(VW/WW2)  
37°(RGBW)
- ・DMXチャンネル : 1/2/4/6 ch(CW/WW/WW2)  
3/4/4ChR/5/6 ch(VW)  
6/7/10/4(HSIC) ch(RGBW)
- ・コントロール : DMX
- ・ソフト更新 : DMX link
- ・ディスプレイ : LED
- ・信号プラグ : 3-pin or 5-pin IP XLR
- ・電源プラグ : 防水パワコン
- ・防水 : IP×4
- ・入力電圧 : AC100~240V、50/60Hz
- ・消費電力 : 235W
- ・機材サイズ : 400×215×200mm
- ・重量 : 6.8 k g



## 寸法図

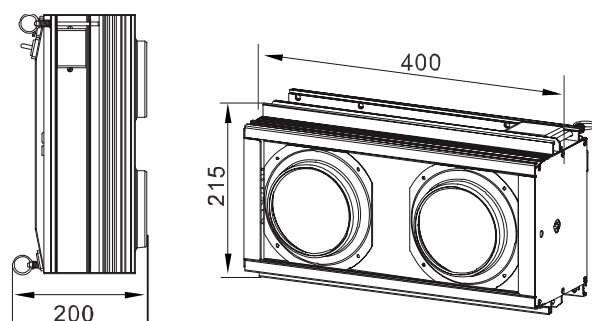



# STAGE BLINDER IP BL-200



Effects

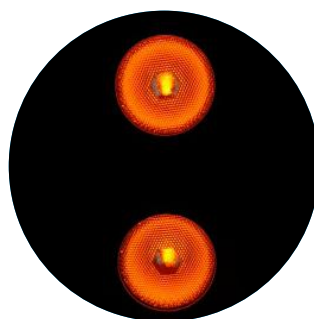

Joint schematics

